



S-GA.305

DEPARTMENT OF TRADE AND COMMERCE
STANDARDS BRANCH

OTTAWA, August 31, 1964.

TYPE APPROVAL

CAMCO "ORIFICE VALVE" and "ORIFICE DOOR"

The apparatus specified and illustrated herein has been duly approved by the Standards Branch under the provisions of the Gas Inspection Act, Chapter 129, R.S. 1952, and may be admitted to verification in Canada.

Apparatus Approved: "Orifice Valve" and "Orifice Door", manufactured by Camco Inc., Houston, Texas, U.S.A., and distributed in Canada by Camco Ltd., Box 4416, Edmonton, Alta.

Rating of Apparatus: 1. Orifice Valve
(a) Flange Type - either raised face or ring type
(b) Flange-Weld Type - weld neck inlet and flanged outlet

<u>Pipe Diameter</u>	<u>Pressure Rating</u>
2 and 3 inch	150 lb. ASA 275 p.s.i. Gauge C.W.P.
"	300 lb. ASA 720 p.s.i. Gauge C.W.P.
"	600 lb. ASA 1440 p.s.i. Gauge C.W.P.

(c) Weld neck Type
2 and 3 inch 600 lb. ASA 1440 p.s.i. Gauge C.W.P.

2. Orifice Door
(a) Flange Type - either raised face or ring type
(b) Flange-Weld type - weld neck inlet and flanged outlet

<u>Pipe Diameter</u>	<u>Pressure Rating</u>
2 and 3 inch	150 lb. ASA 230 p.s.i. Gauge C.W.P.
"	300 lb. ASA 600 p.s.i. Gauge C.W.P.
"	600 lb. ASA 1200 p.s.i. Gauge C.W.P.

(c) Weld neck Type
2 and 3 inch 1440 p.s.i. Gauge C.W.P.

...../2

- 2 -

(d) Socket weld and Threaded Types (female)

2 and 3 inch 1200 p.s.i. Gauge C.W.P.
 Connections (Differential Pressure) 2" N.P.T. Female

Description:

The ball-type "Orifice Valve" is designed to provide both an orifice fitting and a valve so that orifice plates may be easily replaced, while the line is under pressure. The ball part of the valve incorporates a suitable slot for an orifice plate retainer as well as three pressure tap holes. Two of these, located one inch from the orifice plate and on each side of it, are linked with the upstream and downstream orifice pressure connections, and the third one, at the upstream side connects to the lower end of the ball chamber covered with a metal door. This chamber also connects via a shut-off valve to a pressure hole at the upstream side of the orifice pipe. The shut-off valve permits equalizing the pressure in the ball chamber with the line pressure prior to opening the 'Orifice Valve'. A second valve connecting to the same chamber permits bleeding the pressure to the atmosphere before opening the door and removing orifice plate retainer. Suitable method of locking the 'Orifice Valve' in the 'open' position is provided by a spring-loaded lock which must be depressed before the valve can be closed.

The main ball is held in place by the two end pipe pieces screwed on to the main valve body. At their contact ends with the ball they carry circular, self-lubricating, moly-filled teflon seals. Other seals within the assembly are provided by suitable O-rings.

The "Orifice Door" is designed for a quick change of orifice plates in an installation where the line can be relieved of pressure. It is constructed to accept the same type of the orifice plate retainer as the 'Orifice Valve'. The orifice plate itself is of a special design with a grooved rim at the edge. It is held and properly sealed in its retainer by an O-ring.

Both 'Orifice Valve' and 'Orifice Door' are designed to meet the requirements of the A.G.A. Report #J.

R. W. MacLean
 R. W. MacLean,
 Director,
 Standards Branch.

Ref: SL-100-38.

L. G. Anderson
 Acting Chief,
 Electricity and Gas Division,
 Standards Branch.

CAMCO "ORIFICE VALVE" AND "ORIFICE DOWN"

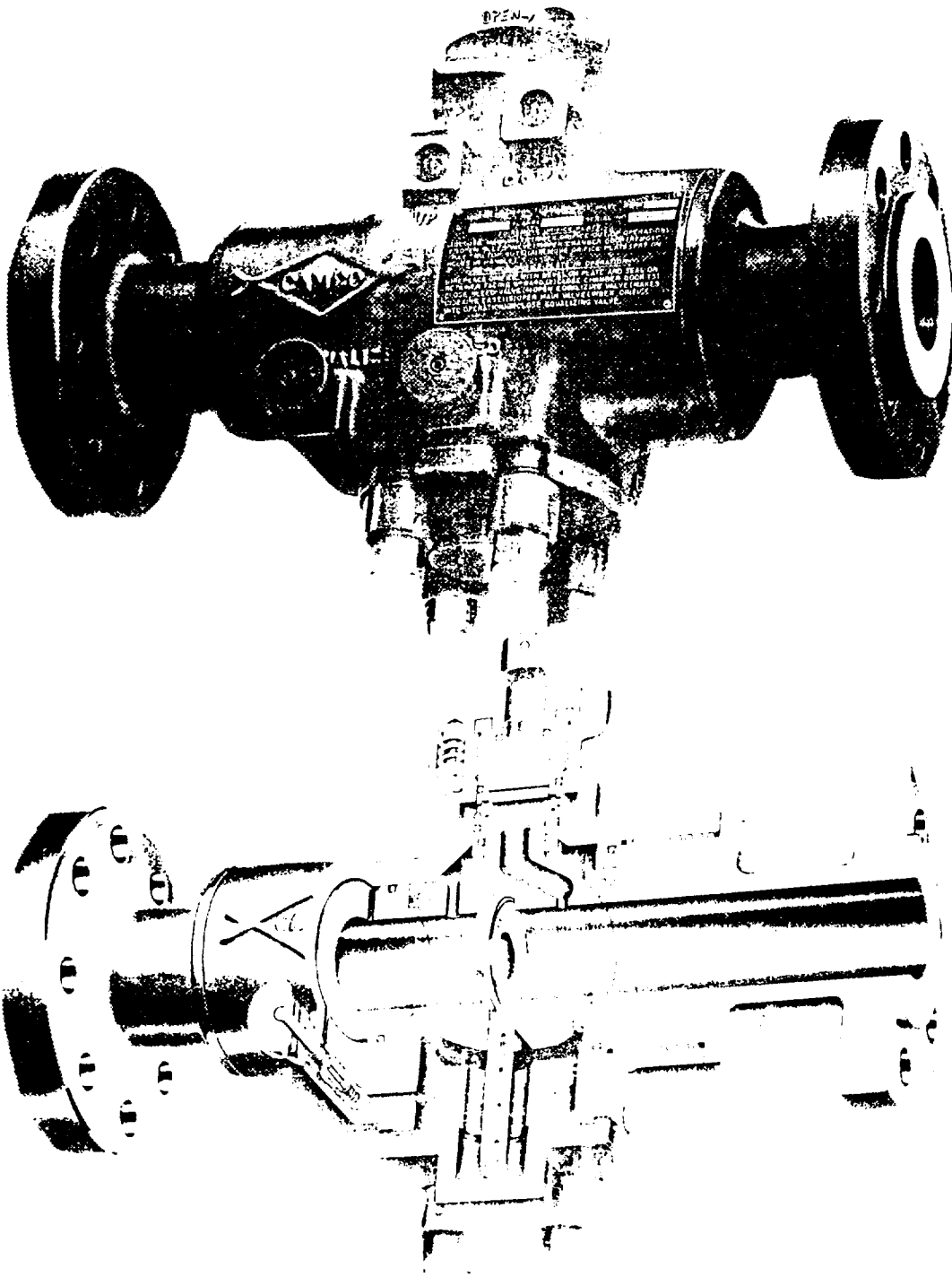

CAMCO "ORIFICE VALVE" AND "ORIFICE DOOR"

