



Department of consumer and corporate affairs / Ministère de la consommation et des corporations



STANDARDS BRANCH - DIRECTION DES NORMES

**NOTICE OF APPROVAL
AVIS D'APPROBATION**

G-98-1

OTTAWA November 28, 1973.

ROCKWELL TP SERIES, RIGHT-ANGLE
TURBO GAS METERS

This Approval Notice supersedes G-98, April 24, 1973

	<u>Model TP-4</u>	<u>Model TP-9</u>
Rated capacity at line conditions, cu. ft./hr.	4,000	9,000
Capacity per rev. of meter output shaft, cu. ft.	10	100
Maximum working pressure, psig	275, 720, 1440	275, 720, 14
Meter connections, flange	2"	3"
Impulse contactor [*] volume per pulse, cu. ft.	10	100
Capacity of counter-type register, digits	4	5
Capacity of lowest digit, cu. ft.	1,000	1,000
Test dial capacity, cu. ft. per rev.	10	100

* Contactor switch ratings are:

- (i) Maximum 900 pulses per hour,
- (ii) Maximum D.C. 200 volts, 10 watts,
- (iii) Maximum A.C. 120 volts, 60 Hz, 14 volt-amperes.

- Note:
1. Any meter which, in service, is not fitted with an approved auxiliary volume correcting device (e.g. one which has a conventional clock or counter type register) is APPROVED FOR USE ON LOW PRESSURE ONLY of approximately seven ounces per square inch or less.
 2. The use of impulse contactor output in remote billing is approved only for low pressure applications, as in note No. 1, when suitable and approved remote counters or receivers are employed.

Description

The Rockwell Right-Angle Turbo-Meter measures gas by utilizing the basic principle of a turbine. The direction of the flow of gas is changed by 90 degrees as it passes through the meter. The inlet to the meter may be in the horizontal or vertical flow line.

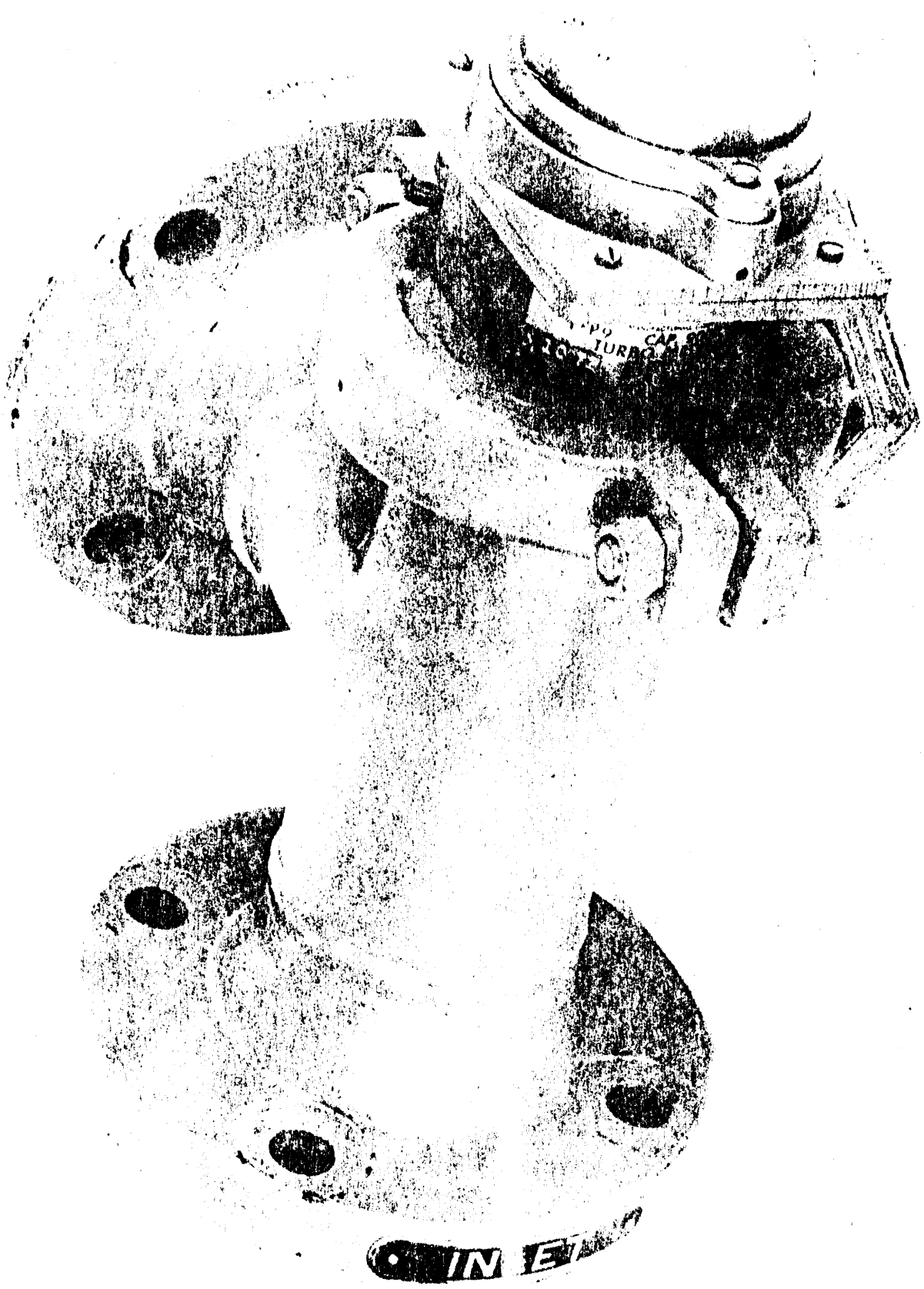

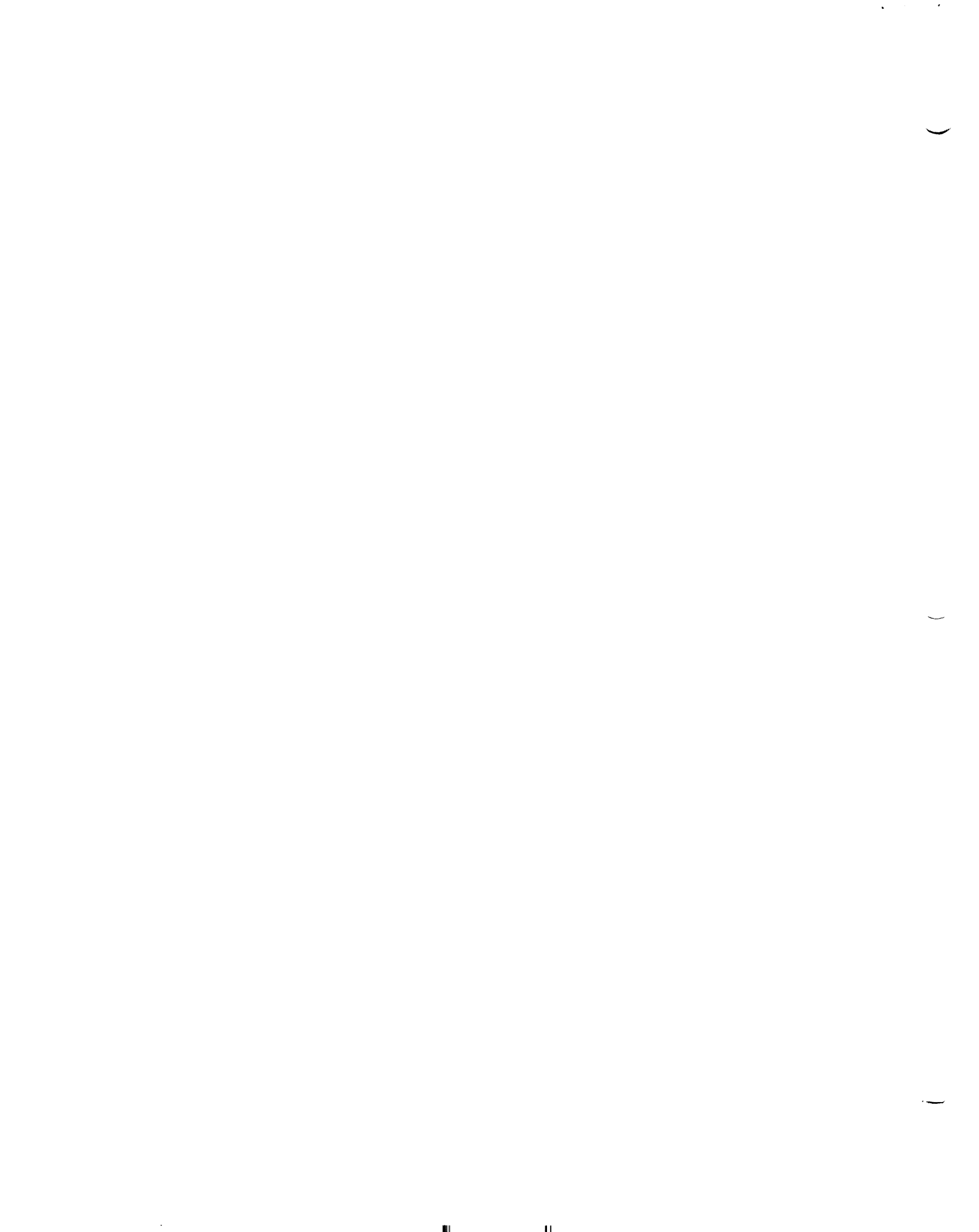

The meter consists of two basic assemblies: (a) the steel meter body, machined and fitted with a nose cone at its inlet, and (b) the removable measuring module assembly which contains the turbine rotor with its bearings, the gear train housing assembly, the change gears by which meter's accuracy can be adjusted and the intermediate gear housing assembly with a magnetically operated reed switch which provides for remote registration of metered volume.

The measuring module assembly may carry either a direct digital index, when used for low pressure measurement as noted above, or a volume correcting device. When the meter is installed with its inlet in the horizontal line, a 90 degrees adapter is required for mounting a volume correcting device on the meter, as shown on the illustration. This adapter has a one to one gear ratio and incorporates provisions for changing the direction of rotation of its output shaft by repositioning of a gear at the right angle drive.

In operation the gas which enters the meter is deflected around the inlet nose cone thus increasing its velocity prior to impinging on the rotor. The passage of the gas stream over the rotor blades exerts a force that causes the rotor to revolve with a speed directly proportional to the rate of flow of the gas. However, should the gas stream enter the meter with a swirling motion, or have a non-uniform velocity distribution (sometimes referred to as jetting) the proportionality of the rotor speed to the flow rate may be upset and meter accuracy affected.

The rated capacity of the meter indicates the maximum permissible flow rate in cubic feet per hour at actual line conditions (maximum dial rate) and this rate applies to all operating pressures. The lowest rate of flow that can produce meter registration with acceptable accuracy depends on the velocity and the density of the gas passing through the meter. As the operating pressure increases, the rangeability of the meter also increases due to the increased density of gas. Manufacturer's bulletins list the rangeabilities for these meters as a function of inlet pressure for a 0.6 specific gravity gas, at standard conditions, for the tolerance level of $\pm 1\%$. The rangeability of a turbine meter depends also on the size of the meter and it may be noted that the 3 inch size TP 9 meter has approximately twice the rangeability of the 2 inch size TP 4 Turbo meter. It is important to take this into account when sizing the meter for the anticipated load.

The turbo-meter measures gas volume at line conditions and when these fluctuate and billing volume refers to other than meter conditions, suitable and approved volume correcting devices shall be used to account for changes in volume caused by the effects of temperature and pressure.

The computation of the volume of a gas, at the contract temperature and pressure, which has been registered in cubic feet at line conditions is based on the ideal gas laws modified by a deviation factor available in the form of a Supercompressibility factor (F_{pv}), determined according to the A. G. A. Gas Measurement Committee Report No. 3, Orifice Metering of Natural Gas.

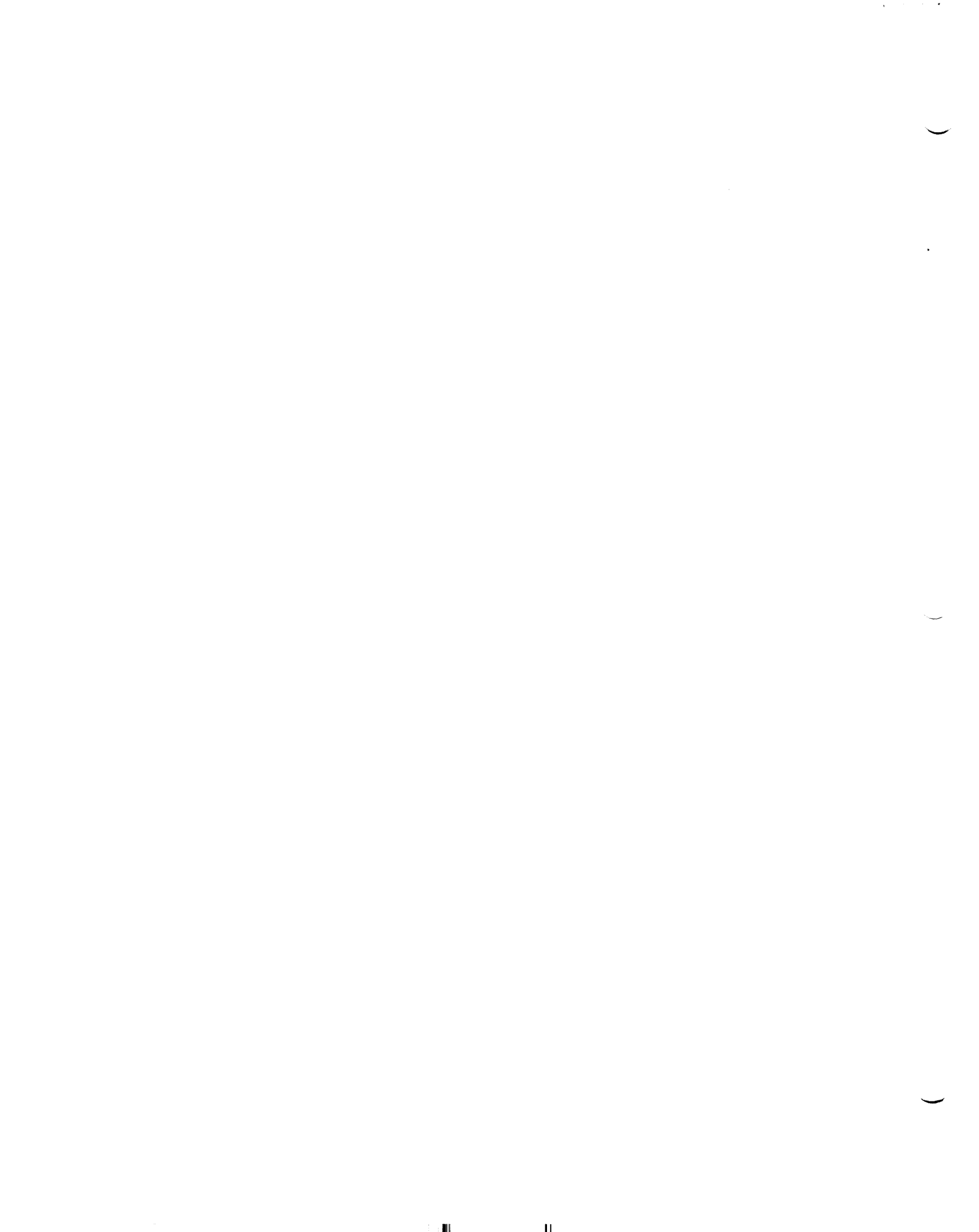

MEASURING MODULE ASSEMBLY LESS INTERMEDIATE GEARING ASSEMBLY

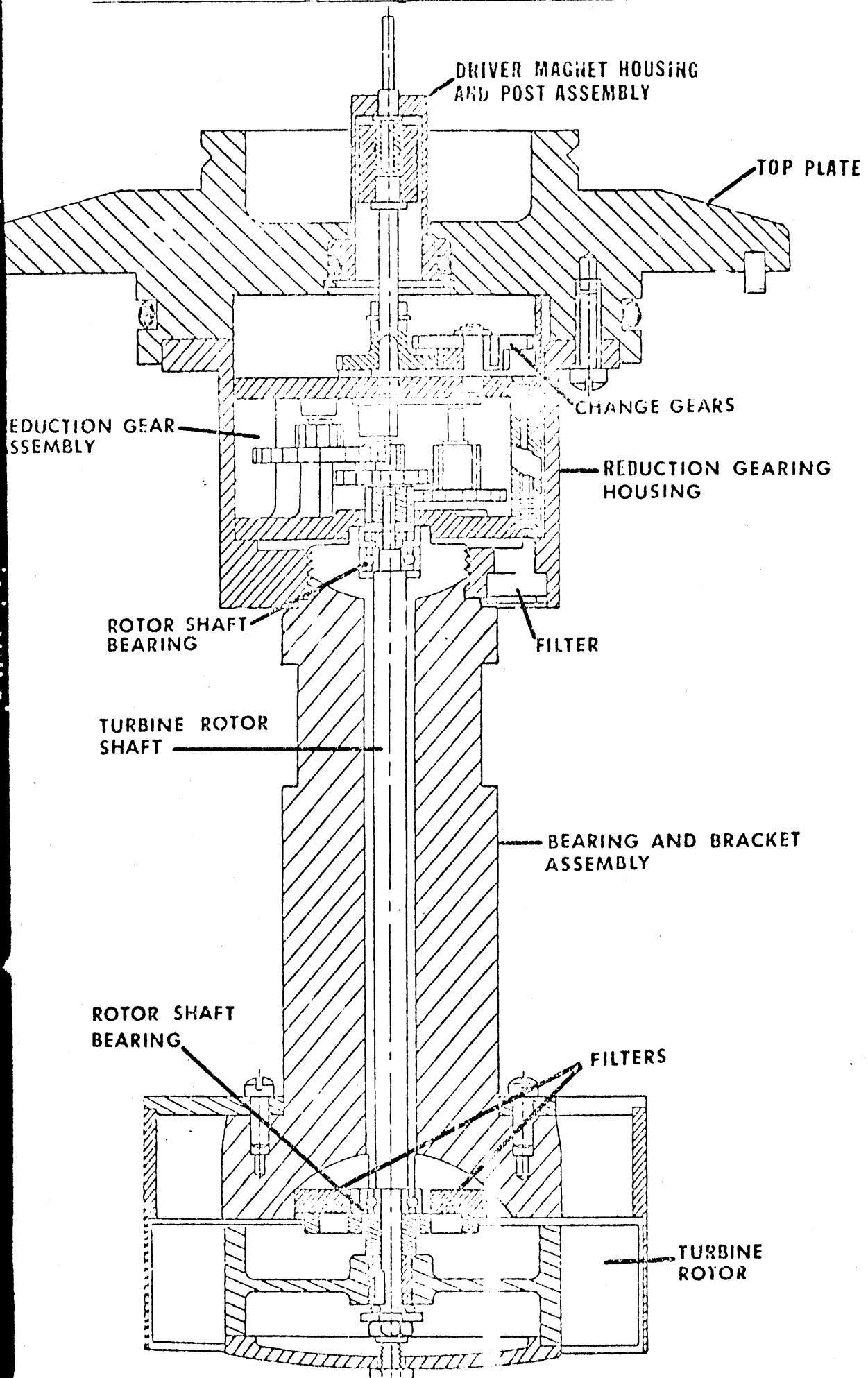

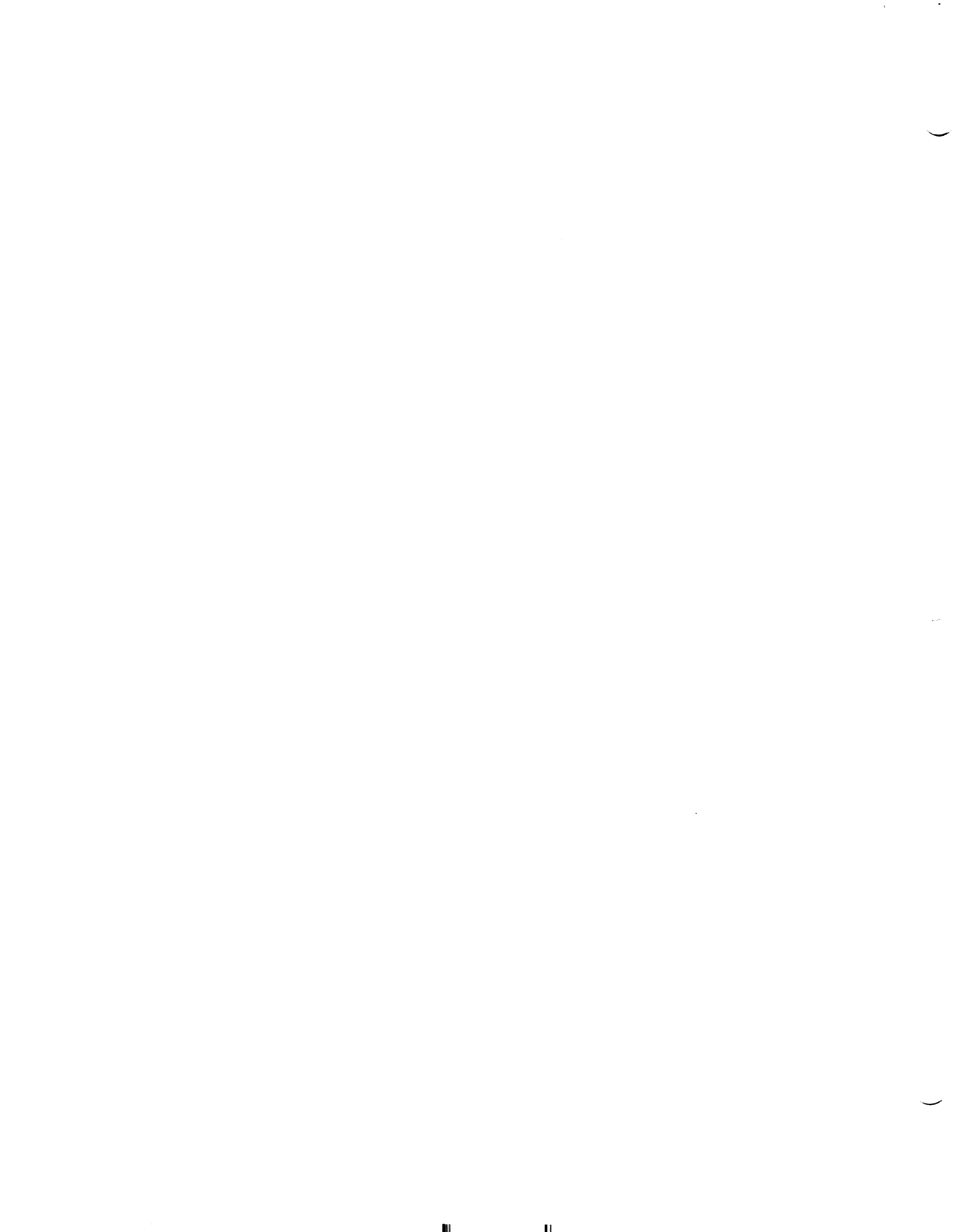

The general equation for converting the meter readings at line conditions to a contract base pressure and temperature is

$$Q_s = Q_d P_m T_m (F_{pv})^2$$

Q_s = Quantity of gas at the contract base pressure and temperature, cu. ft.

Q_d = Actual (displaced) gas passed at existing meter conditions, cu. ft.

P_m = Pressure multiplier

$$= \frac{\text{Weighted average existing gauge pressure} + \text{barometric pressure}}{\text{Absolute pressure base}}$$

T_m = Temperature multiplier

$$= \frac{\text{Temperature base} + 460}{\text{Weighted average flowing gas temperature} + 460}$$

F_{pv} = Supercompressibility factor based upon the weighted average gas pressure and temperature and the normal composition of the gas. The composition is represented by its specific gravity, its content of nitrogen and carbon dioxide and its calorific value as used in the derivation of F_{pv} values.

The selection of the weighted average supercompressibility factor F_{pv} , should be based on a record of the flowing gas volumes, pressures and temperatures. Whether or not a continuous record is available, the variations in pressure and temperature normally existing in the line must not introduce an error greater than $\pm 0.5\%$ from the selected $(F_{pv})^2$ factor.

Installation

The TP Turbo meters may be installed with the inlet to the meter in either horizontal or vertical flow line. When in the latter configuration the flow must be in the upward direction. All installations must have a minimum straight run, of the meter size pipe, five diameters long at the inlet side of the meter. At the upstream side, the straight run must have straightening vanes conforming to the specifications of the A. G. A. Report No. 3. The straight run may be preceded by an elbow or a tee. The meter outlet may be connected directly to the line.

Except as noted below, the pressure taps for connecting pressure recorders or volume correcting devices are located on the meters as shown in the illustrations on pages 8 and 9. A few meters, however, have been supplied without a pressure tap. In such cases a pressure tap shall be located in straight, unobstructed, upstream pipe not less than one pipe diameter nor more than four pipe diameters from the meter inlet.

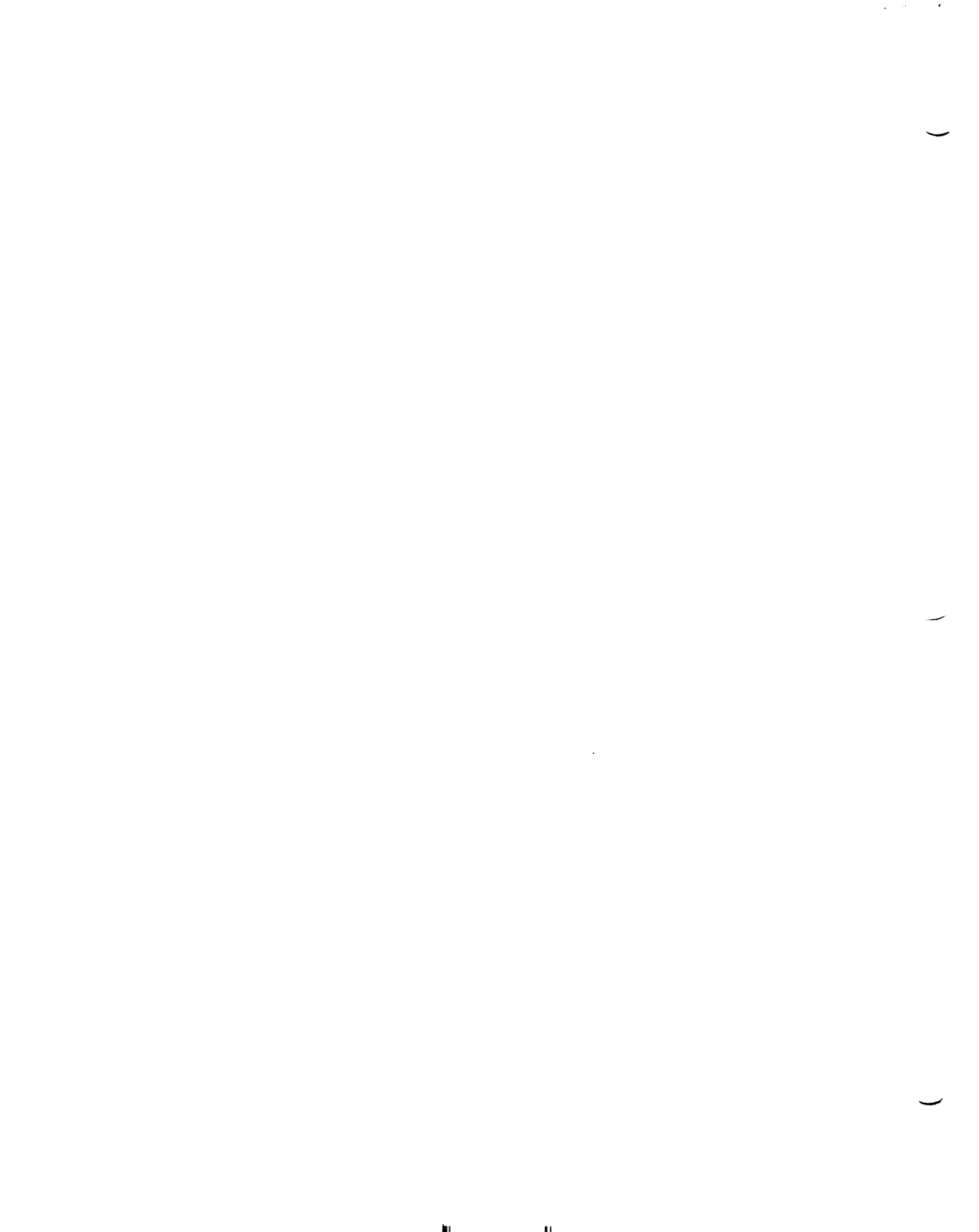

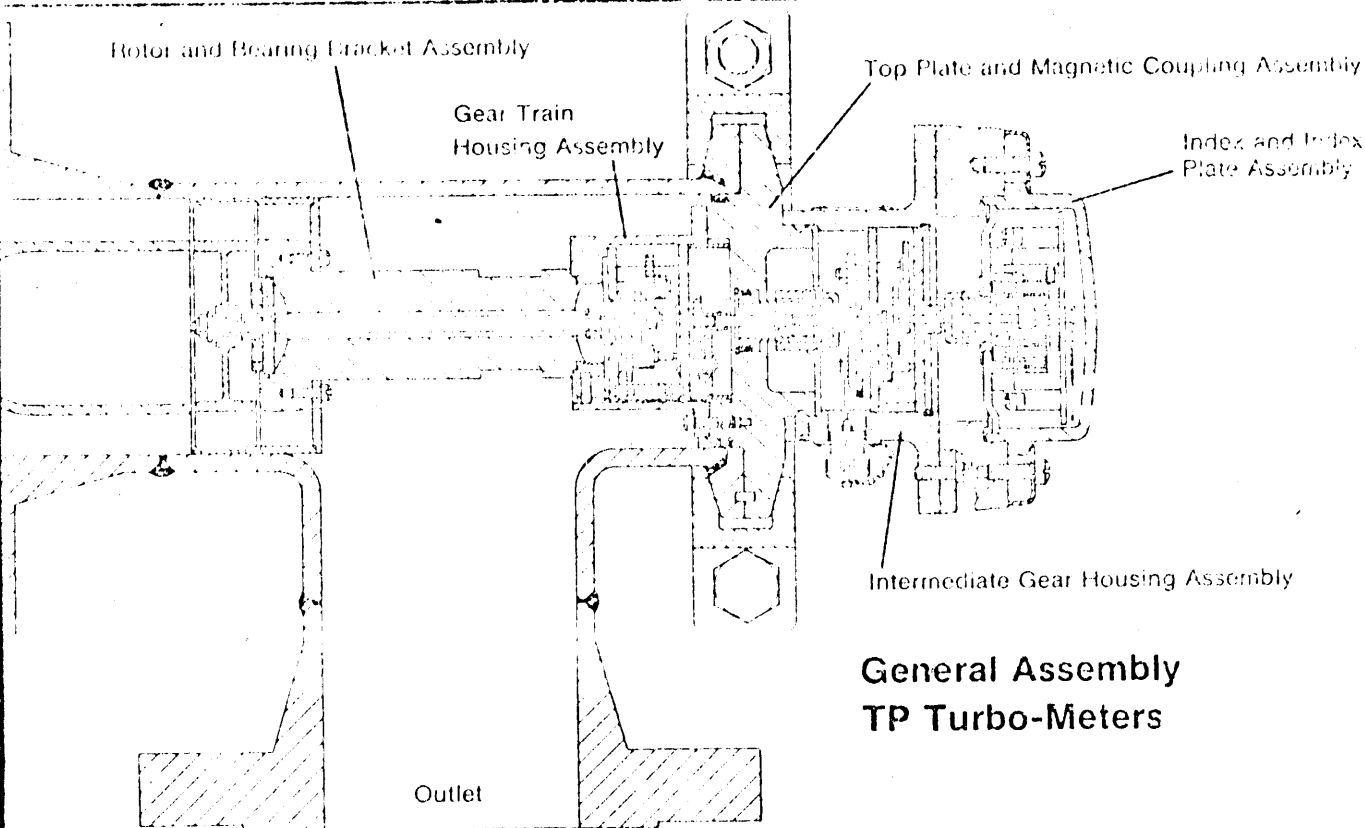

VERTICAL
AND
HORIZONTAL
MOUNTING

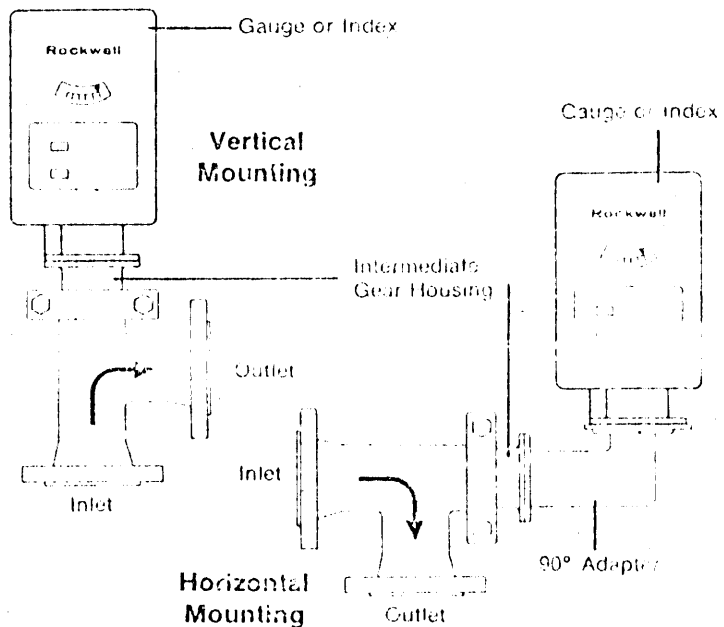



A temperature probe may be located upstream of the meter, ahead of the straightening vanes by at least one pipe diameter length, or downstream in a position that does not interfere with the discharge from the meter, usually at a distance of about two pipe diameters.

Except where loads are seasonal or may be interrupted without disadvantage to the customer, it is strongly recommended that by-pass and test connections be installed.

All meters verified for service shall have the Gear Train Housing Assembly sealed by the government inspector to the Top Plate and Magnetic Coupling Assembly to prevent the access to the Change Gears by which the accuracy of the meter may be altered.

It shall be the responsibility of the utility to seal the screws holding the half-clamp brackets, the meter index, the volume correcting device and the 90 degrees adapter, where applicable. Suitable provisions for the above sealing shall be made by the manufacturer.

Each meter shall have a nameplate, or nameplates, containing the following information:

- (1) Manufacturer's name
- (2) Model designation
- (3) Rate capacity, cu. ft.
- (4) Maximum working pressure, p.s.i.g.
- (5) Manufacturer's serial number

Approval granted to:

Rockwell Manufacturing Company
of Canada, Limited,
Guelph, Ontario

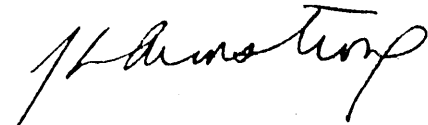
J.L. Armstrong
Chief, Standards Laboratory,
Metrology and Laboratory Services

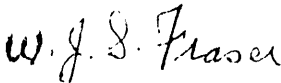
W.J.S. Fraser
Chief, Electricity & Gas Division,
Metrology and Laboratory Services

Ref: GL-1147-57/R2-166

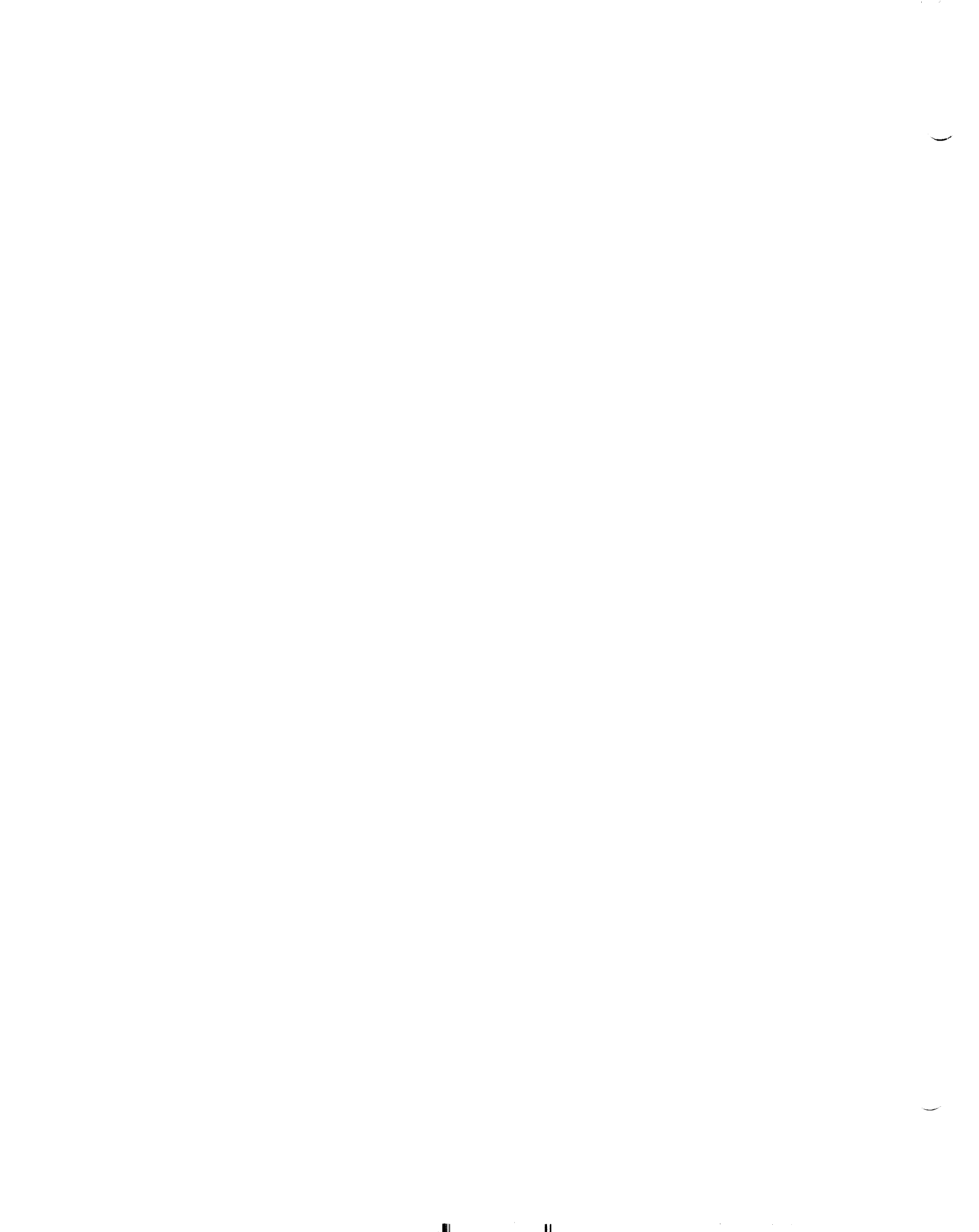

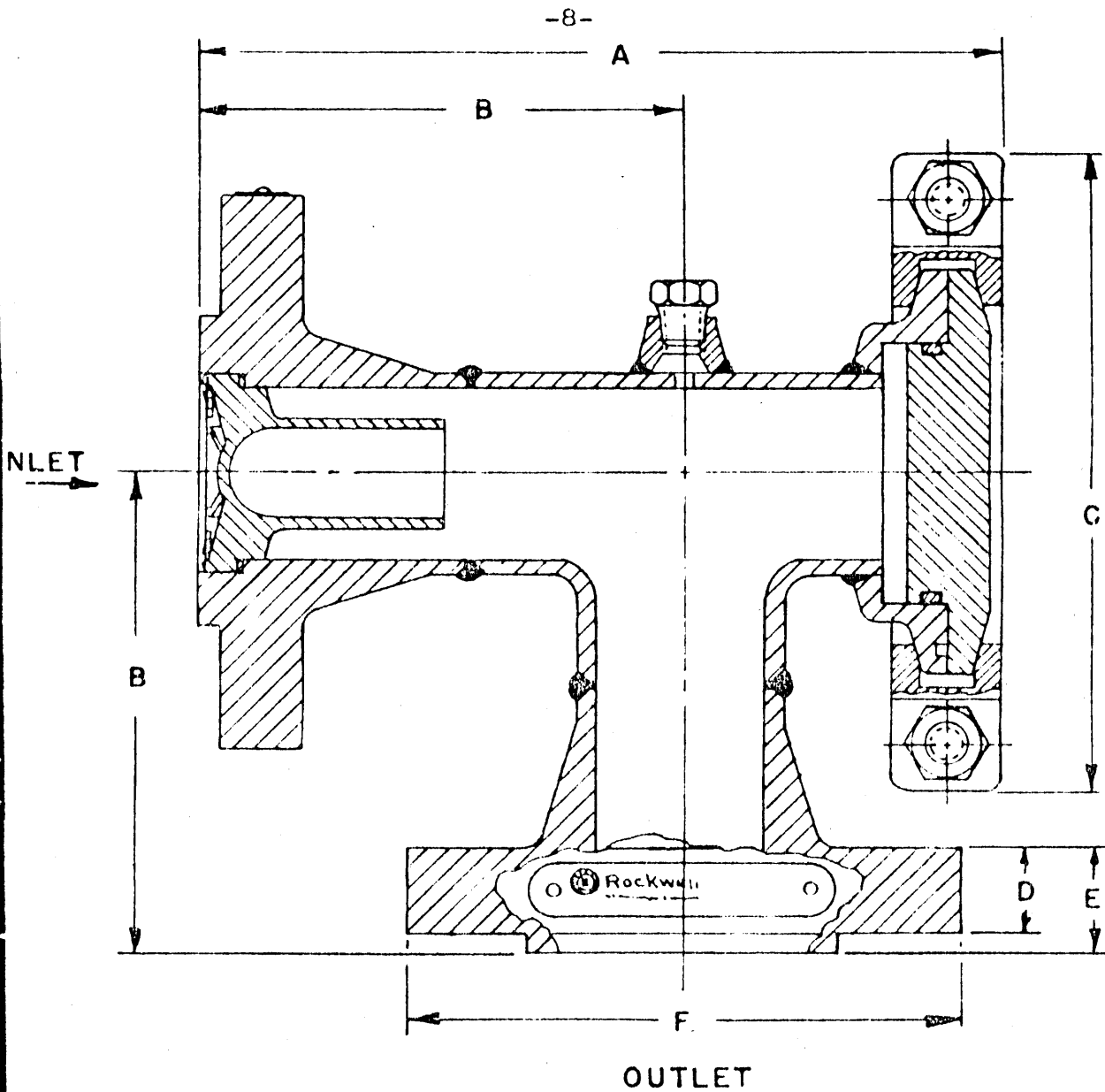

PRESSURE RATING	PART NO.	DIMENSIONS					
		A	B	C	D	E	F
AN 150 (275 ^{psi})	006-16-600-00	8 ^{13/16} ± .004	5 ^{1/16} + ⁰ / _{-1/8}	7 ^{5/8}	1 ^{1/16} "	3/4"	6"
AN 300 (720 ^{psi})	006-16-600-50	9 ^{1/16} ± .004	5 ^{5/16} ± .008	7 ^{5/8}	1 ^{3/16} "	7/8"	6 ^{1/2} "
AN 500 (1440 ^{psi})	006-16-600-80	9 ^{7/16} ± .004	5 ^{1/16} ± .008	7 ^{5/8}	1"	1 ^{1/4} "	6 ^{1/2} "

NOTE:
FLANGE SPECIFICATIONS CONFORM TO ANSI B16.5.

REV	DATE	 Rockwell MANUFACTURING COMPANY	DuBois, PENNSYLVANIA
		TP-4 2" BODY MODULE ASSEMBLY	
		DATE ISSUED	MM-1408
		MAR. 21, 1973	

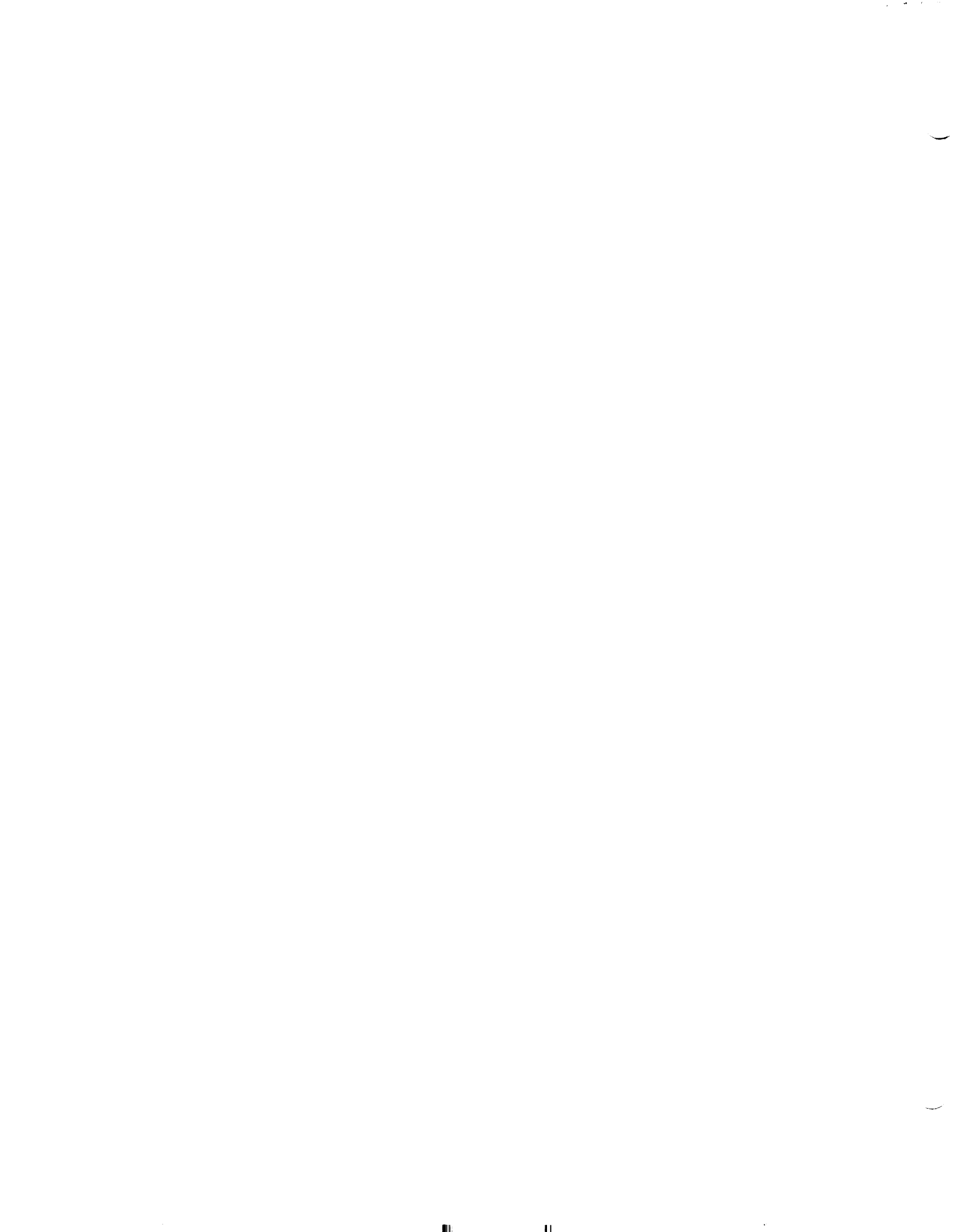

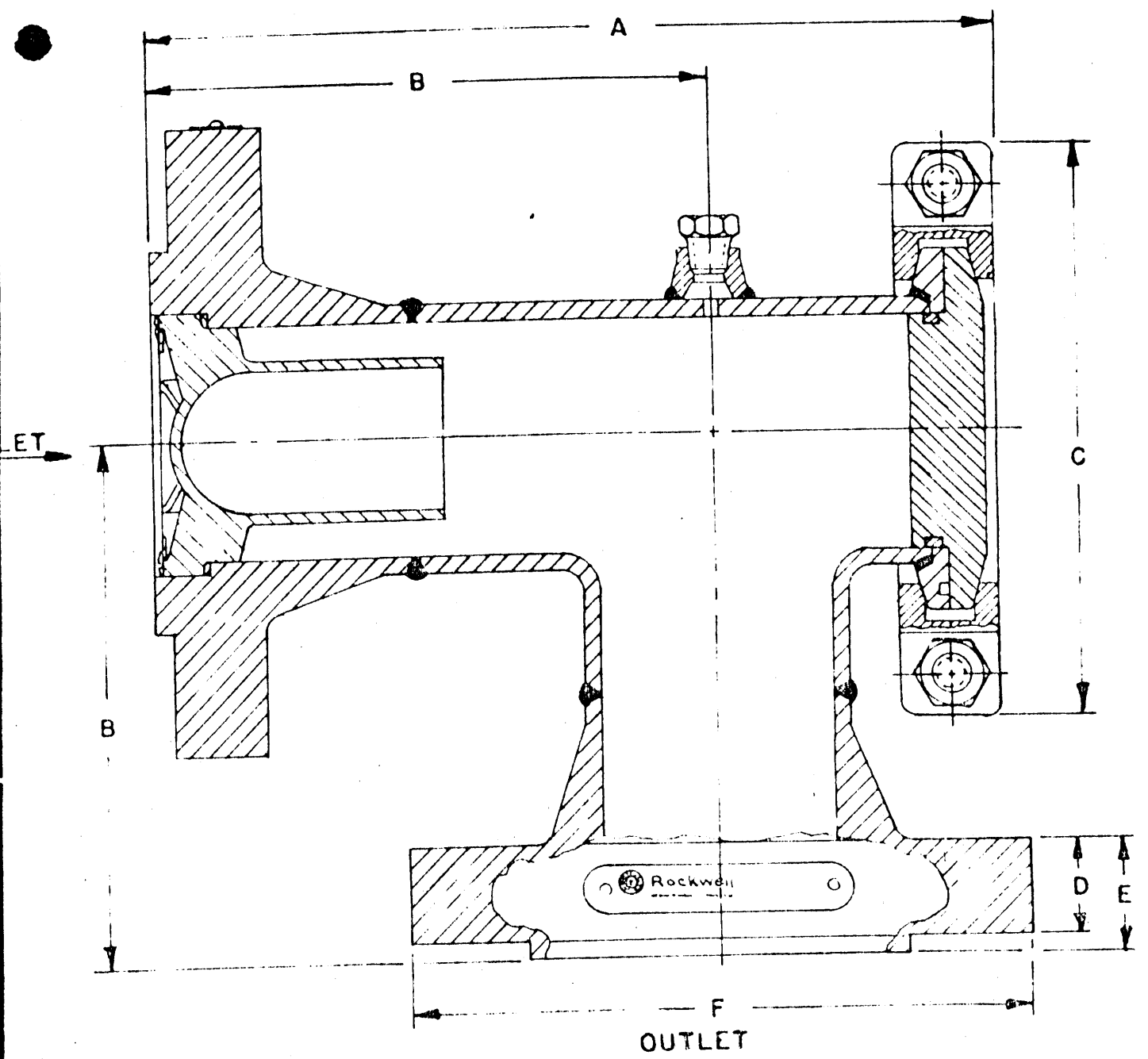

PRESSURE RATING	PART NO.	DIMENSIONS					
		A	B	C	D	E	F
ANSI. 150 (275#)	006-20-600-00	$10\frac{13}{32} \pm \frac{1}{64}$	$6\frac{3}{16} \pm \frac{9}{8}$	7 5/8"	7 1/8"	15/16"	7 1/2"
ANSI. 300 (720#)	006-20-600-50	$10\frac{25}{32} \pm \frac{1}{64}$	$6\frac{9}{16} \pm \frac{9}{8}$	7 5/8"	1 1/16"	1 1/8"	8 1/4"
ANSI. 60Q (1440#)	006-20-600-80	$11\frac{5}{32} \pm \frac{1}{64}$	$6\frac{15}{16} \pm \frac{9}{8}$	7 5/8"	1 1/4"	1 1/2"	8 1/4"

NOTE:
 FLANGE SPECIFICATIONS CONFORM
 TO ANSI B16.5

REV	DATE	 Rockwell MANUFACTURING COMPANY	DUBOIS PENNSYLVANIA
		TP-9 3" BODY MODULE ASSEMBLY	
		DATE ISSUED MAR 22, 1973	MM-1409

