



Department of consumer and corporate affairs / Ministère de la consommation et des corporations



STANDARDS BRANCH - DIRECTION DES NORMES

**NOTICE OF APPROVAL
AVIS D'APPROBATION**

G-69-2 and
G-70-1

OTTAWA June 28, 1973

MODIFICATION TO
ROCKWELL EMCORECTOR TYPES I AND T

Approval Circulars G-69-1, dated May 10, 1972 and
G-70, dated December 22, 1970 remain in force.

Description

Rockwell Manufacturing Company has introduced a
new type of clutch for the above instrument.

The mounting bracket of the new clutch is cast
aluminum. The sleeve bearings and the spring have been
replaced by roller bearings and ball thrust race. The
new clutch is somewhat smaller in size.

Attached illustration shows both versions of the
clutch.

Approval granted to:

Rockwell Manufacturing Company,
Guelph, Ontario.

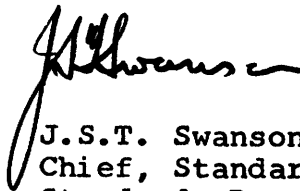
J.S.T. Swanson, P. Eng.,
Chief, Standards Laboratory,
Standards Branch.

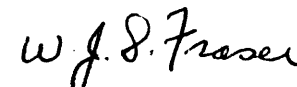
W.J.S. Fraser,
Chief, Electricity & Gas Division,
Standards Branch.

Ref: G 1147-57/R2-771

OLD CLUTCH DESIGN

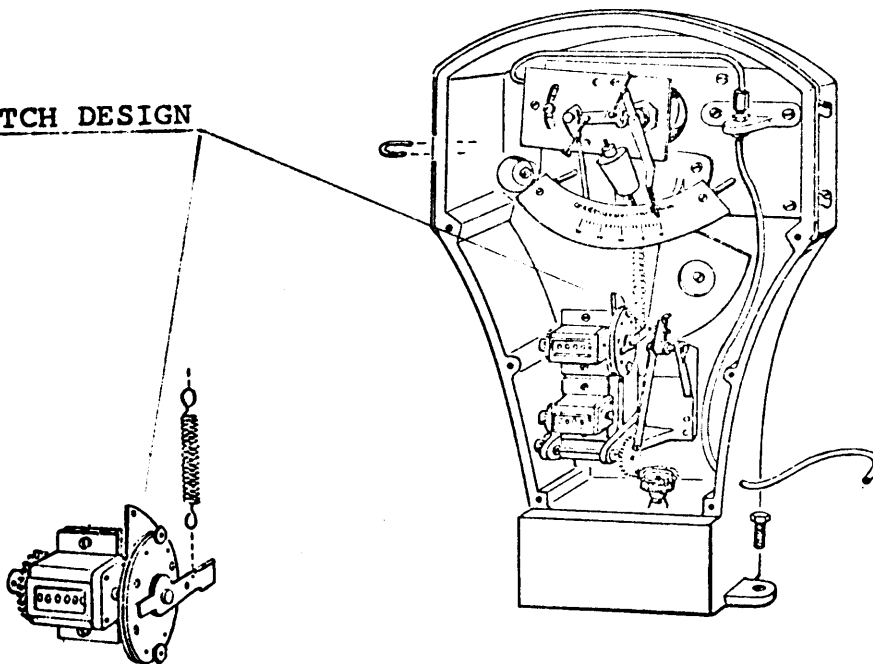

NEW CLUTCH DESIGN

