



Consumer and
Corporate Affairs Canada

Consommation
et Corporations Canada

Legal Metrology
Branch

Direction de la
Métrologie légale

Holland Avenue
Ottawa, Ontario
K1A 0C9

Avenue Holland
Ottawa, Ontario
K1A 0C9

Your file *Votre référence*

Our file *Notre référence*

Telephone: (613)952-0639

File N°: 06635
Project: AP-GL-91-0045

Rosemount Instruments Ltd.
808 - 55th Avenue, N.E.
Calgary, Alberta
T2E 6Y4
Attn.: Mr. Peter Baker

1992-02-27

Dear Mr. Baker,

This is in response to your recent notification given in accordance with the Electricity and Gas Inspection Regulations, Section 13, regarding devices approved under Notice of Approval G-0179 dated 1986-06-24. It is noted that these devices are to be modified as follows:

- The sensor wiring input terminal cover is to be elongated, to provide splash protection to the zero LED indicator and adjusting potentiometer. Refer to attached illustrations.
- Note: Rosemount Instruments Ltd. provides the "electronic package" which forms a major component of the CNG dispensers approved in G-0179.

I am advised by the Gas Metrology Laboratory that their evaluation of the proposed modifications indicates that they may be regarded as immaterial in relation to the approval provisions of the Act. Accordingly, your notification is acknowledged and the modifications are accepted as being included within the above-noted approval. All recipients of the approval notice are being informed by copy of this letter.

Yours truly,

W.R. Virtue, Chief
Legal Metrology Laboratories

cc: Approvals Mailing List

Canada

PREVIOUS TERMINAL COVER

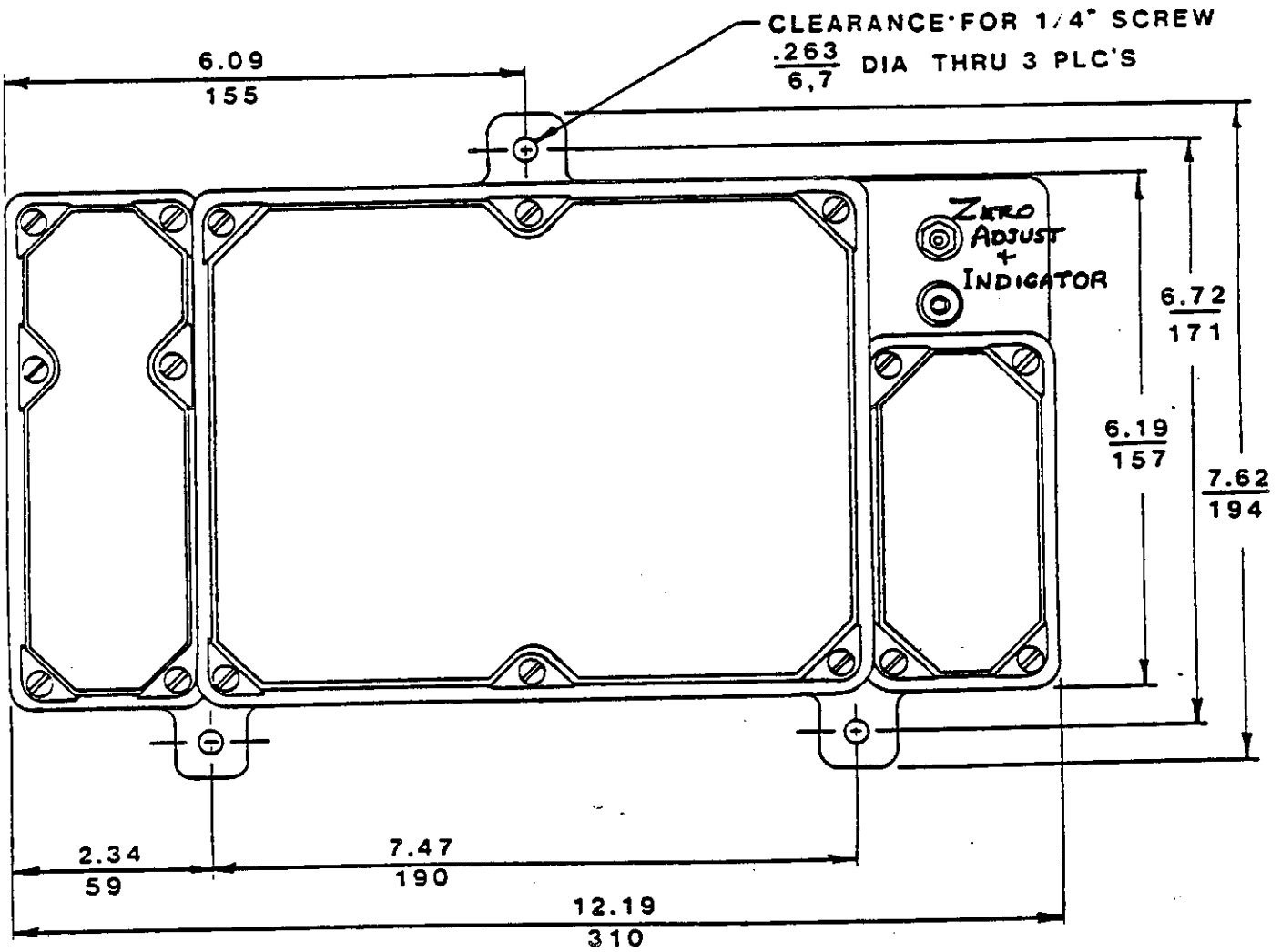

MODIFIED TERMINAL COVER

