



Consumer and
Corporate Affairs.

Consommation et
corporations

Standards

Normes

NOTICE OF APPROVAL
AVIS D'APPROBATION

G-115

Ottawa, January 29, 1976

ROCKWELL PRESSURE REGULATOR
MODEL 243 RPC

Apparatus

Maximum Inlet Pressure, (1)	psig	30 to 125
Outlet Pressure Range		Up to 35 psig
Approved Maximum Flow	0.6 Sp.Gr. (2)	
Gas, SCFH as per Capacity Table, (2)		
Page 4 of Rockwell Bulletin R1343		
Main Orifice Diameters		1/4", 3/8", 1/2", 3/4", 1", 1-1/4"
Regulator Connections		
(a) screwed NPT		1-1/4", 1-1/2", 2"
(b) ANSI 125 lb flanged		2"

- (1) Refer to Rockwell Bulletin R1343, page 3 for Maximum Inlet Pressures based on various orifice and pipe sizes.
- (2) Approved maximum flow is determined by the minimum inlet pressure of a system in which the regulator is installed.

Approval is hereby granted for the use of the above named apparatus in Pressure Factor Measurement installations.

Description

This model is a pilot operated type, that is, it uses a smaller "power pilot" to produce a variable gas pressure on the main diaphragm. For example, if the pressure downstream decreases, this reduction in pressure will be transmitted to the underside of the diaphragm of the power pilot and of the main valve, via the control line. (The control line is connected to the downstream piping as shown in Figure 2.) The power pilot responds to this

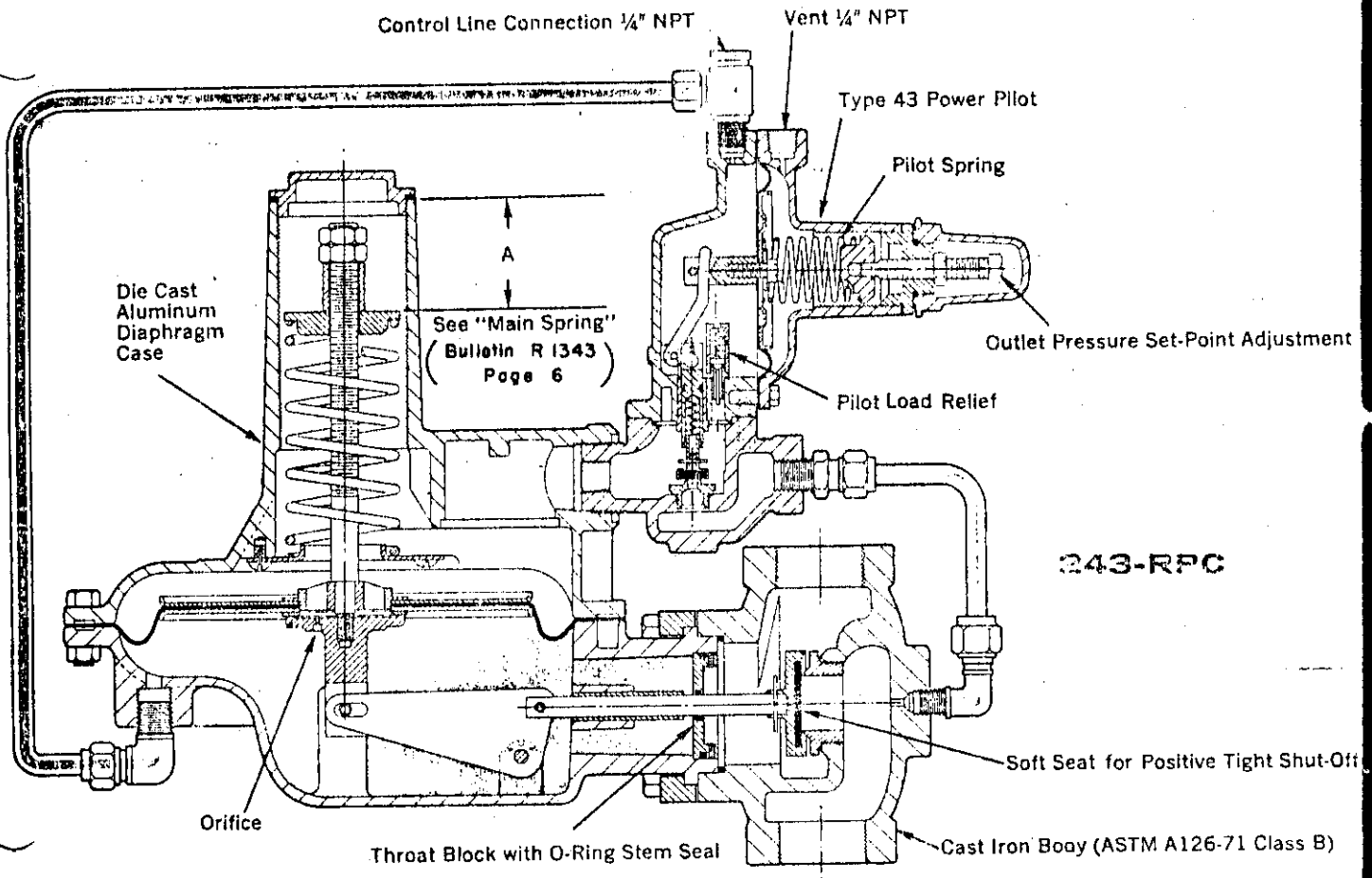

FIGURE 1
CROSS-SECTIONAL VIEW

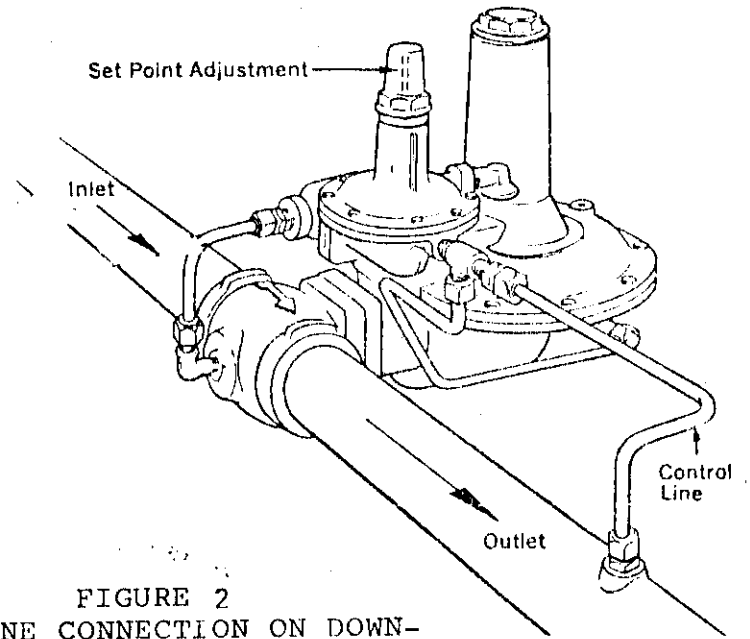
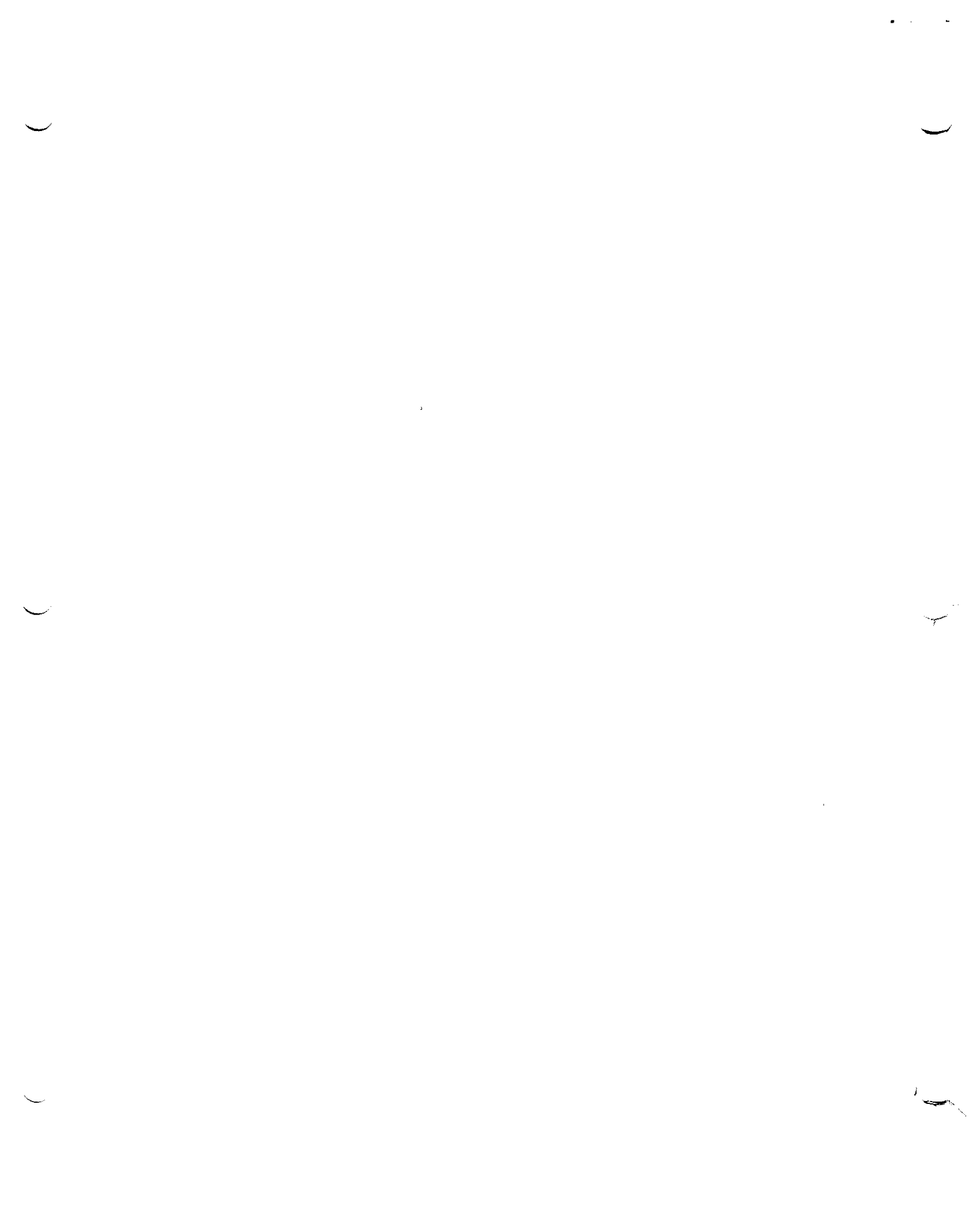

FIGURE 2
CONTROL LINE CONNECTION ON DOWN-
STREAM PIPING FOR A TYPICAL
INSTALLATION



change in pressure by increasing the flow of gas into the chamber above the main diaphragm. Simultaneously, the reduction in pressure will allow the main diaphragm to move down. This opens the main valve which increases the flow to match the demand. In this way the outlet pressure is returned to the regulated value.

The main diaphragm has a small bleed orifice which allows a continuous flow from the upper to lower portion of the main diaphragm. (Refer to Figure 1, Cross-Sectional View.) Thus, the flow from the power pilot is continuously released to the downstream piping via the bleed orifice and the control line.

All capacities listed in Rockwell Bulletin R1343 are based on a set point flow of 250 SCFH. For further details regarding set-point adjustment and recommended methods of installation refer to the Rockwell bulletin.

For field testing procedure refer to Technical Gas Circular G-75-3.

Approval granted to:

Rockwell International of Canada Ltd.,
Guelph, Ontario.

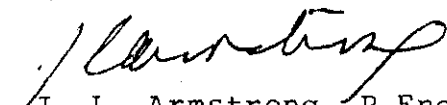
J. L. Armstrong, P.Eng.,
Chief, Standards Laboratory,
Metrology and Laboratory Services.

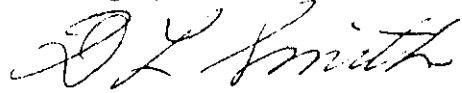
D. L. Smith, P.Eng.,
Chief, Electricity & Gas Division,
Metrology and Laboratory Services.

Ref: GL: 1147-57/R2-183

